

ARJOHUNTLEIGH

GETINGE GROUP

ENTERPRISE 5000

E5X RANGE



...with people in mind



DESIGNED FOR YOU AND YOUR PATIENT

The new Enterprise® 5000 hospital bed from ArjoHuntleigh delivers significant benefits to patient, caregiver and healthcare facility. The daily challenges faced by nursing teams on hospital wards have inspired ArjoHuntleigh to improve upon an established solution, trusted by hospitals around the globe. In the development of the new *Enterprise* 5000 hospital bed, ArjoHuntleigh has focused on key customer needs common to all healthcare environments, namely:

- Safety for both patient and carer.
- Compliance with new international standards.
- Equipment that is robust, intuitive and easy to use.
- Solutions focused on the quality of care for patients.





SAFETY

A safe environment is critical to the well-being of patients and carers. Falls affect as many as 10% of older adults during an acute care inpatient stay¹ and can result in serious and often life-threatening injuries.

Caregivers are also at risk, with more than 80% of US nurses suffering an injury directly related to patient handling at some point in their career².

The new *Enterprise 5000* aims to reduce the risk of injury for staff and provide a safer environment for the caregiver.



- ACP (Attendant Control Panel) controls are backlit to ensure safe and consistent operation during evening or low light levels.
- Extra low height – a key advantage in reducing the risk of injury through falls.
- Underbed lighting – the bed exit area on both sides of the bed is illuminated to help improve patient safety and security.



THE NEW BED STANDARD

Developed by the International Electrotechnical Commission (IEC), the IEC60601-2-52:2009 Standard is the new benchmark for medical bed performance and safety. Whilst the standard covers many aspects including electrical safety, load bearing, stability and durability, one of the main requirements focuses on reducing risk of patient entrapment in and around the bed frame.

Use of extensive incident and risk data has enabled the IEC to identify a number of areas around the bed (illustrated below) where entrapment of a patient's head, neck or chest might result in a serious or life-threatening situation. By prescribing stringent test parameters for these areas, the aim is to reduce entrapment risks to the minimum possible level during operation and use of the bed.

The new *Enterprise 5000* has been independently tested by a globally renowned organisation, to certify that it is compliant with the latest stability, dimensional and safety requirements of the IEC60601-2-52 Standard.





INTUITIVE OPERATION AND EASE OF USE

Our one-button-push controls are intuitive and easy to use, thanks to clear and simple icons. One touch functions can be used for key features, such as:

- Auto CPR
- 30 degree backrest angle
- Auto-contour
- Cardiac chair position
- Low height and extra low height
- Trendelenberg / reverse Trendelenberg

Some or all of these functions may be locked out by the caregiver if required.



A choice of patient handsets is available.



THREE POSITION BED EXTENSION

Different bed lengths are now easily configurable in a single sub-frame, offering greater flexibility and choice:

- Short 219cm
- Standard 230cm
- Extended 242cm

This new design also integrates an extendable deck sheet to ensure full mattress support at each length.



ENHANCING THE QUALITY OF CARE



The backrest will pause when raised to an angle of 30 degrees, ensuring easy and positive backrest adjustment time after time. Studies show that the 30 degree backrest angle is the minimum requirement for providing recognised physical, postural and clinical benefits³.



The caregiver can easily adjust the bed into a cardiac chair position with our simple to use control panel, by selecting the appropriate icon.



Backrest angle indicators provide easy to read information for crucial head elevation measurements.

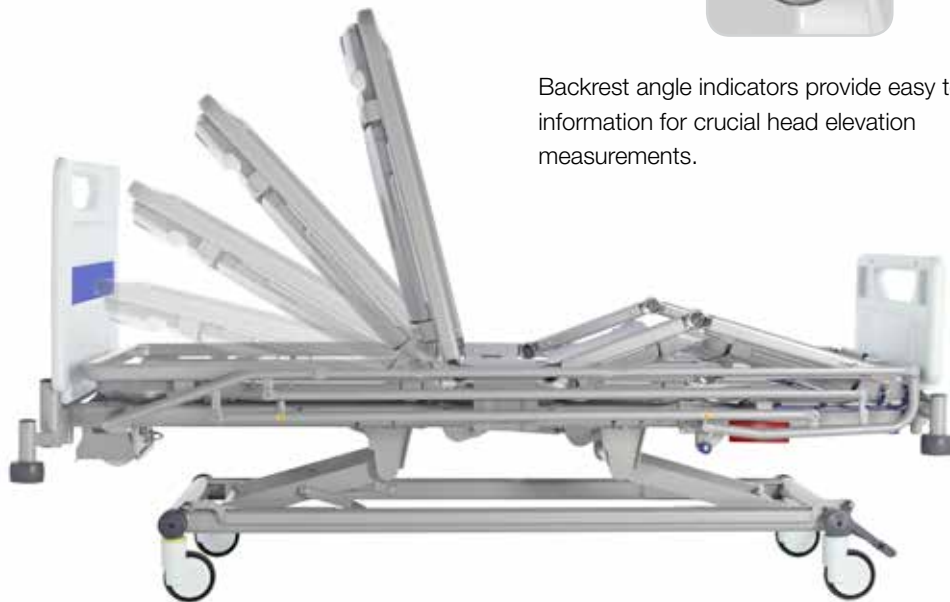

Pressure ulcers are one of the most common preventable wounds in healthcare facilities, with prevalence rates in European hospitals of up to 23%⁴. Pressure ulcers are most likely to develop when a person is immobile and spends prolonged periods on surfaces that do not provide appropriate pressure redistribution.

Our patented 'Bio-Contour' design blends a unique combination of bed section movements with a curved mattress platform, designed to assist in the management of pressure and shear – the main cause of pressure ulcers.

CLEANING, MAINTENANCE AND SERVICE



The *Enterprise 5000* is designed with open architecture and no base cover to allow ease of access for cleaning and decontamination.



Blow moulded decksheets and head/foot panels are lightweight, smooth and easily removable to aid cleaning. The linen shelf option assists in reducing cross-infection risks.



Pit stop maintenance is achieved by designing open accessibility and plug and play components. Changes such as actuator, control box and battery can be carried out in situ within a few minutes by one trained person.



Equipment is designed to be easy to service and maintain, reducing time spent on cleaning, service and maintenance activities.

OPTIONS



Linen Shelf



Control Box Cover



Patient Handsets



Din Rail



Underbed Light



Head End Pedal



Brake Bar



Castors



The panel infill colours available for the head / foot board are:

- Light Blue
- Lilac
- Dark Blue.

ACCESSORIES



Standard IV Pole



Lifting Poles



ACP Holder



Heavy Duty IV Pole



Urine Bottle Holder



Transducer Mount



Full Frame Traction



Syringe Pump Holder



Oxygen Cylinder Holder

LIFTING POLES & FOLDING MONITOR SHELF	IV POLES & HOOKS	TRACTION & TRANSDUCER POLES	PUSH HANDLES, SIDE RAIL PADS, OTHER	SYRINGE PUMP, O ₂ HOLDER, URINE BOTTLE HOLDER
Fixed LP with Strap and Handle ENT-ACC01	Standard IV Pole ENT-ACC02	Small Traction Assembly ENT-ACC10	ITU Head End Panel ENT-ACC34	Syringe Pump Holder ENT-ACC07
Rotating LP with Strap and Handle ENT-ACC03	Angled IV Pole ENT-ACC04	Full Frame Traction ENT-ACC05	Pads For Side Rails ENT-ACC06	Oxygen Cylinder Holder ENT-ACC08
LP Mounted IV Bag Holder ENT-ACC13	Heavy Duty IV Pole ENT-ACC24	Head End Traction Assembly ENT-ACC32	ACP Holder ENT-ACC11	Oxygen Bottle Holder (B5 Cylinder) ENT-ACC18
Folding Monitor shelf ENT-ACC64	Additional IV Pole Hooks ENT-ACC14	Transducer Mounting Pole ENT-ACC26	Mains Cable Hook ENT-ACC15	Urine Bottle Holder ENT-ACC19

PRODUCT SPECIFICATIONS

FEATURES	
Electrically operated backrest, knee-break and height adjustment	•
Electrically operated Trendelenberg / Reverse Trendelenberg tilt	±12°
Auto-CPR and Auto-contour button	•
Battery back-up	•
Bio-Contour profiling system	•
One button chair position	•
Dual sided CPR levers	•
30° backrest angle pause	•
Angle indicators for backrest	•
Built-in bed extension with mattress platform extension	•
Removable head and foot panels with choice of colour infills	•
Drainage bag rails	•
Removable plastic deck sheets	•
Linked braking / steering system with four braking castors	•
125mm single wheel castors	(•)
150mm single wheel castors	(•)
150mm twin wheel castors	(•)
Additional brake pedals at head end	(•)
Full width brake bar (foot end only)	(•)
DIN rails	(•)
Under-bed light	(•)
Folding safety sides	(•)
Pull-out linen shelf	(•)

• Standard (•) Optional

SPECIFICATIONS	
Overall standard length	2300mm
Overall width	1030mm
Mattress length standard	2020mm
Mattress width	880mm
Overall extended length	2420mm
Mattress extended length	2140mm
Overall length short	2190mm
Mattress length short	1910mm
Top height (with 125mm castors)	760mm
Low height (with 125mm castors)	320mm
Backrest length	850mm
Seat length	215mm
Calf length	560mm
Thigh length	365mm
Safe working load/Maximum patient weight	250kg/185kg
Head down tilt	12°
Foot down tilt	12°
Backrest angle	62°
Backrest pause	30°
Thigh angle	20°
Calf angle	16°
Ingress protection	IPX4
Shock protection	Class 1, Type B
Power in	1.25A at 230V AC 50 / 60Hz
Power in	2A at 120V AC 50 / 60Hz
Safety standard	IEC60601-2-52

ArjoHuntleigh is a branch of Arjo Ltd Med. AB. Only ArjoHuntleigh designed parts, which are designed specifically for the purpose, should be used on the equipment and products supplied by ArjoHuntleigh. As our policy is one of continuous development we reserve the right to modify designs and specifications without prior notice. © and ™ are trademarks belonging to the ArjoHuntleigh group of companies. © ArjoHuntleigh, 2013

References:

1. McCarter-Bayer A, Bayer F, Hall K Preventing falls in acute care: an innovative approach. Journal of Gerontological Nursing (2005), 31(3):25-33
2. Cohen, M. et al. (2010) PHAMA Patient Handling And Movement Assessment. The Facility Guidelines Institute.
3. Tablan OC, Anderson LJ, Besser R, et al. Guidelines for prevention of health-care-associated pneumonia, 2003: Recommendations of CDC and the Healthcare Infection Control Practices Advisory Committee. MMWR Recomm Rep. 2004;53 (RR-3):1-36.
4. Vanderwee K, Clark M, Dealey C, Gunningberg L, Defloor T. Pressure ulcer prevalence in Europe: a pilot study. Journal of Evaluation in Clinical Practice 2007;13(2):227-35.

ARJOHUNTLEIGH
GETINGE GROUP

www.ArjoHuntleigh.com

GETINGE GROUP is a leading global provider of products and systems that contribute to quality enhancement and cost efficiency within healthcare and life sciences. We operate under the three brands of **ArjoHuntleigh**, **GETINGE** and **MAQUET**. **ArjoHuntleigh** focuses on patient mobility and wound management solutions. **GETINGE** provides solutions for infection control within healthcare and contamination prevention within life sciences. **MAQUET** specializes in solutions, therapies and products for surgical interventions and intensive care.

ArjoHuntleigh AB
Verkstadsvägen 5
SE-241 38 Eslöv
Sweden

ArjoHuntleigh International Ltd
Houghton Hall Business Park
Houghton Regis
Bedfordshire, LU5 5XF, United Kingdom
Phone: +44 1582 745 800
Fax: +44 1582 745 866
E-mail: international@arjohuntleigh.com

